

JPE 2-4-3

A Study on Solution against Core Saturation Instability at HVDC Converter

¹Byeong-Mo Yang, ¹Chan-Ki Kim*, ¹Bong-Eun Koh, and ²Young-Hyun Moon

¹Korea Electric Power Research Institute, Daejeon Korea

²Dept. of Electrical Engineering, Yonsei University, Seoul Korea

ABSTRACT

The paper identifies a severe form of core saturation instability in a DC/AC interaction system. It then seeks solutions to the problem by HVDC control means. This is achieved by a proper design of the Voltage Dependent Current Order Limiter (VDCOL), the Current Regulator and Timing Pulse generator. Supplementary control loops have also been introduced to result in a satisfactory performance as compared to that obtained one with the use of uncharacteristic harmonic filter on the AC side. All the options have been demonstrated through recovery performance of the DC link in response to both 1-phase and 3-phase 5 cycle faults on both rectifier and inverter commutating buses.

Keywords: Core saturation instability, DC/AC interaction system, Voltage Dependent Current Order Limiter, Timing Pulse Generator, Firing Angle Modulation, Current Order Modulation

1. Introduction

Long distances large power transmission can be carried out by HVDC connection cheaper than by a long distance AC transmission line. Also, Bulk power of HVDC transmission scheme, as shown in Fig 1, may be transmitted through very long cables or across borders where the two AC systems are not synchronized or operating at the same frequency.

However an HVDC converter generally acts as a source of harmonic currents of the AC side and harmonic voltages on the DC side. As the DC power transmission rating increases, the harmonics (both characteristic and

uncharacteristic) generated by an link also increase in magnitude. So use of tuned filters for the low order characteristic harmonics and high pass (HP) damped filters for higher harmonics is a normal design practice. Uncharacteristic harmonics injected into poorly damped resonant networks can then become a difficult operating condition for then DC/AC system. This low order harmonic resonance can get more severe if there is a DC side series resonance at the complementary frequency of resonance in the AC side.

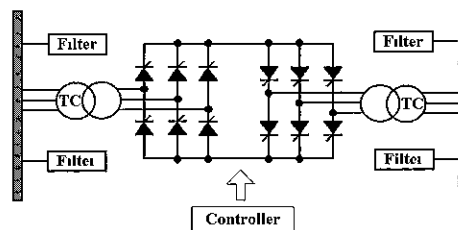

Fig 1 HVDC system scheme.

Manuscript received April 9, 2002, revised Sept 10, 2002

Corresponding Author: ckkim@kepri.re.kr, Tel +82-42-865-5892, Fax +82-42-865-5844

The simulation of 'steady-state' core saturation instability or interaction is difficult in a traditional digital transients environment because of the long time constants involved in saturating the converter transformers and the relatively low levels of DC exciting currents in the valve windings of the converter transformers. This paper investigates the usefulness of HVDC control modifications for a configuration which suffers from a severe form of low order harmonic resonance problems due to core saturation instability phenomenon. Also, it presents some new control modifications which make the use of uncharacteristic harmonic filters redundant. The investigation is performed by the time domain digital simulation using the EMTDC program.

2. Review for Core Saturation Instability

A very complex nonlinear interaction called core-saturation instability can disrupt HVDC performance [1][2][3][4][5][7]. This closed-loop interaction involves the AC and HVDC system resonances, transformer saturation converters, and the converter control and it is most likely to occur in a system with second-harmonic AC impedance resonance and fundamental DC admittance resonance.

This interaction, in simple terms, is described by the following. Consider that a minor disturbance has resulted in a small amount of converter transformer core flux offset. This offset causes second-harmonic current to be injected into the AC system. The resulting second-harmonic AC voltage distortion appears as fundamental on the DC side. The fundamental DC ripple is translated by the converter into second harmonic and DC currents. The DC currents can add to the core saturation, and the interaction may grow if the loop gain and phase shifts are sufficient. The HVDC control can respond to the current ripple in such a manner that a small amount of negative damping occurs. Thus, the interaction can grow in magnitude with potentially damaging or disruptive results.

To determine the converter transformer core saturation harmonic contribution, first the effect of a direct current on the transformer magnetization current is examined. It is best to consider the direct current on the transformer secondary and the magnetization current on the transformer primary.

The mechanism of the phenomenon can be easily explained using the block diagram of Fig 2^{[1][2]}

If a small-level positive sequence second-harmonic voltage distortion exists on the AC side of the converter, a fundamental frequency distortion will appear on the DC side. Through the DC side impedance a fundamental frequency current will flow resulting in a positive sequence second-harmonic current and a direct current flowing on the AC side. The direct current flowing on the AC side will begin to saturate the converter transformer, resulting in a multitude of harmonic currents being generated, including the positive sequence second-harmonic current. It will be an additional contribution to the positive sequence second harmonic voltage distortion and in this way the feedback loop is completed. The stability of the system is determined by the characteristics of this feedback loop.

Under the worst-case conditions, the transformer magnetization AC flux is assumed to be reaching the limits of the non-saturated part of its magnetization characteristics as shown in Fig. 3^[9].

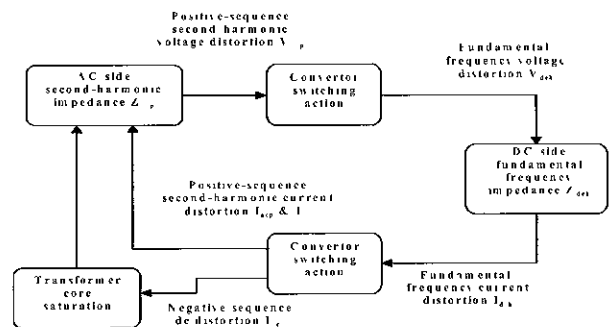

Fig 2 Mechanism of Core saturation instability

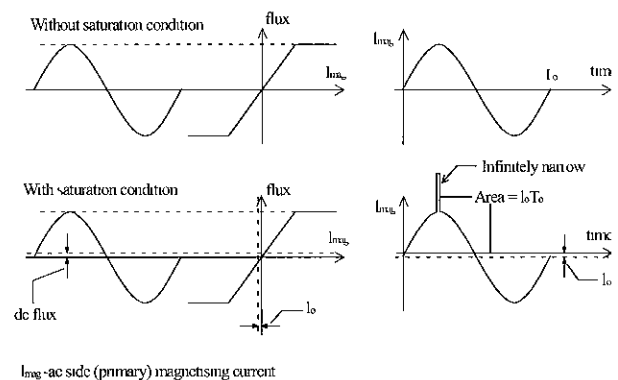

Fig 3 Transformer saturation

Under such conditions, even a small DC bias will force an asymmetrical magnetization current and cause transformer saturation to occur in one half of the fundamental cycle

To solve this problems, the following methods has researched

- A. Tuned filter installation method on AC side
- B. VDCOL changing method
- C. Optimizing method of the current regulator
- D. Firing angle modulation method

2.1 Tuned Filter Installation on AC Side

HVDC converter acts, from the AC point of view, as a source of harmonic currents, and from DC point of view, as a source of harmonic voltage one of the methods to solve this problem is the use of a filter, as shown in Fig 4

But a filter installation method has not ability to remove unexpected non-characteristics harmonics And the installation of additional filters for unexpected non-characteristics harmonics is not economics Because of the complexity and costs of filters there have been several methods to achieve harmonics control by other means as followings.

- Magnetic flux compensation
- Harmonic injection

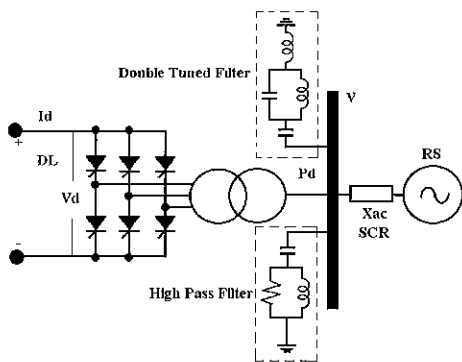

Fig 4 Turned filter installation method on AC side

2.2 Change in Voltage Dependent Current Order Limiter (VDCOL)

The need of VDCOL is for the implementation to control not only DC current to be contained when the DC voltage falls but th current to be reduced. In Fig. 5(a), VDCOL is found useful only where the AC systems on both rectifier and inverter can support fast recoveries or delayed power reductions after a severe fault

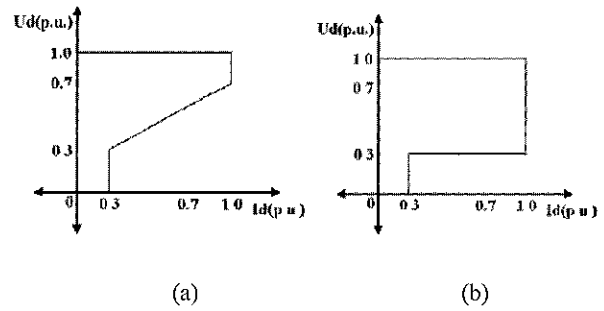

Fig 5 Voltage Dependent Current Order Limiter (VDCOL) Characteristics

But, in weak AC systems with poor damping offered by the loads, it is much better to control the current for recovering AC system with a suitable ramp rate (with time constant) as shown in Fig. 5(b). VDCOL with time constant, as shown in Fig 5(b), is chosen after investigation of operation through a range of disturbances, particularly those involving faults or low voltages VDCOL shown in Fig 5(b) has improved control characteristics for all types faults

2.3 Optimizing the current regulator

In harmonic resonance problem, one can optimize the current regulator by reducing the control gain offered to problematic frequencies, while still maintaining a sufficiently fast dynamic response from the regulator Fig 6 shows the current regulator block diagram of HVDC system But Improvement of this kind is not good enough to guarantee recovery from all faults

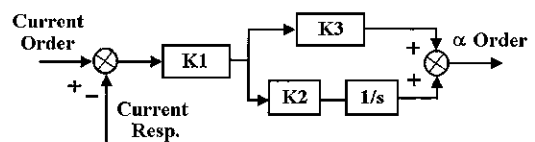

Fig 6 Current Regulator Block Diagram

2.4 Firing angle modulation method

In the presence of unbalance caused by distortion from the ac system, or ac currents arriving on the DC line, or small unbalances within the converter station (e.g commutation reactance unbalances), converter tend to operate in an unbalanced manner. The solution is to modulate firing angles (via the common 12-pulse oscillator) in a closed-loop manner to equalise the 12 γ_s .

The fast main loop still remains to control absolute γ by using γ -balance, 3rd harmonic balance, α -balance method^[8] The DC components in the converter transformer windings can simultaneously eliminate all DC components on the AC side by using Firing Angle Modulation method for Elimination Transformer DC current^[3]

The firing scheme in an HVDC system correspond to the firing of valves at an interval of T/12 seconds for a 12 pulse converter It is therefore possible for the current regulator to correct for changes in the DC current for certain combinations of AC/DC configuration For stable operation of the DC link, it is therefore necessary to reduce the response of the current regulator for undesirable harmonics in the DC current This can be achieved efficiently by subtracting from the firing angle and proportional to the harmonic content in the DC current. This correction has no effect on the current regulator operation or the DC quantities Fig 7 is the block diagram of a filter circuit which is a combination of a low pass and a band pass filter This type of characteristics is desirable to extract mainly the magnitude of frequencies in the band between 3rd and 5th harmonics

This ensures that the correction is not delayed beyond the firing of one valve in a twelve pulse configuration

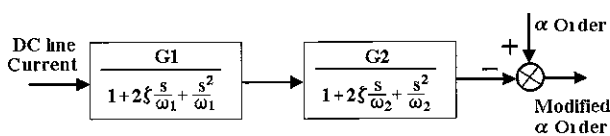

Fig 7 Block diagram of firing angle modulation scheme

3. HVDC Controller Design using Modified PI Controller

In conventional control system, the characteristics of a system PI controller have to have following function

if error is large then K_p is large

if error is small then K_p is small

if error is large then K_i is small

if error is small then K_i is large

where, K_p is the proportional gain and K_i is the integral gain

Since the above equations are a non-linear function in this paper, Fuzzy controller was used to implement the above control function by using conventional PI controller Fuzzy controller can be made by an exponential function or a triangle function. an exponential function is based on linear membership function, otherwise a triangle function is based on crisp function This fuzzy functions have a different advantages each other, an exponential function is can be implemented easily on digital condition or analogue condition

Using membership functions, the gains of the controller are determined

$$\begin{aligned}
 K_p &= \frac{w_1 K_{p1} + w_2 K_{p2}}{w_1 + w_2} \\
 &= \frac{w_1 f_1^{-1}(w_1) + w_2 f_2^{-2}(w_2)}{w_1 + w_2} \quad (1) \\
 &= F(w_1, w_2) \\
 &= F'(error_1, error_2)
 \end{aligned}$$

where, w_1 and w_2 are the membership, that is an exponential function.

Similarly, K_i can be determined Finally, the gains of K_p and K_i are obtained

$$\begin{aligned}
 K_p &= (K_{p1} - K_{p2} e^{K_p 3 error}) \\
 K_i &= K_p e^{-K_p 12 error} \quad (2)
 \end{aligned}$$

The PI gains used in this paper can be arbitrarily determined as long as they are in the range of a stable region. However, comparing to a conventional PI gain, this approach does not guarantee the desired system performance and HVDC system need some particular characteristics to prevent commutation failure and instability caused by AC network Therefore, the selecting method of controller gains are as follows

- 1) Since K_{i2} and K_{p3} determine the system response, this gains correspond to the characteristics of VDCOL response
- 2) Determine K_{p1} , K_{p2} and K_{p3} by classic method
- 3) In order to guarantee stability, select this condition $K_{p1} > K_{p2}$

4. PSCAD/EMTDC Simulation Results

It is difficult to simulate core saturation instability in CIGRE benchmark HVDC systems of Fig. 8 because of damping, So, for the purpose of validating the proposed control method to eliminate core saturation instability, the modified CIGRE benchmark HVDC systems are set up on the PSCAD/EMTDC transient simulation program in Table 1^[6].

The converter-transformer magnetizing current are lowered, from 1% to 0.2%, to achieve a highly susceptible transformer. The transformer leakage reactance is also lowered, from 0.18p.u. to 0.13p.u. to further shorten the commutation period and hence reduce the amount of apparent damping on the system

Rectifier's AC system in Fig 9 has $-0.001623 + j0.009488$ admittance at 2nd harmonic (120Hz) and DC line modified in Table 1 has $0.0005 + j0.010$ [mhos] at 1st harmonic (60Hz)

Simulation results by PDCAD/EMTDC program are as follows:

Second, Fig 10, Fig 11, Fig 12 and Fig. 13 show the effect of filter. The last, Fig 14 show that instability of system by a fault was diminished by robust controller.

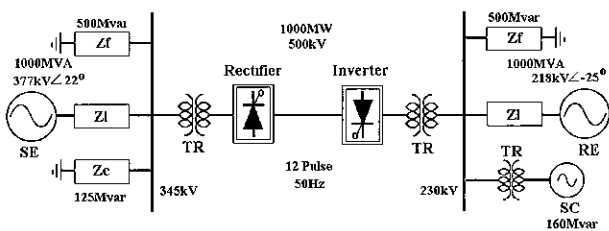

Fig 8 HVDC Model Based on CIGRE MODEL

Table 1 Modified CIGRE Benchmark Model's Parameter

Parameter	Origin value	Modified value
Frequency	50Hz	60Hz
DC line	5Ω, 1 1936H, 26 μF	4 987Ω, 0 5H, 9 2025 μF
AC line	In Fig 6 (R1 100Ω, C1 1000 μF, R2 1030Ω, L2 5 3489H, C2 315 77 μF)	
C Tr knee point	1 22 p u	1 10 p u
C Tr air-core reactance	0.36 p u	0 20 p u
C Tr leakage reactance	0 18 p u	0 12 p u

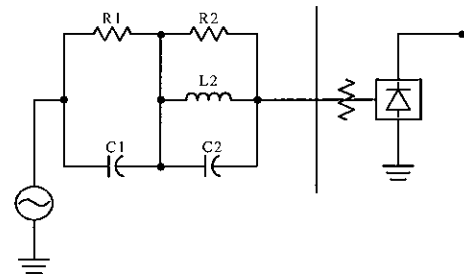
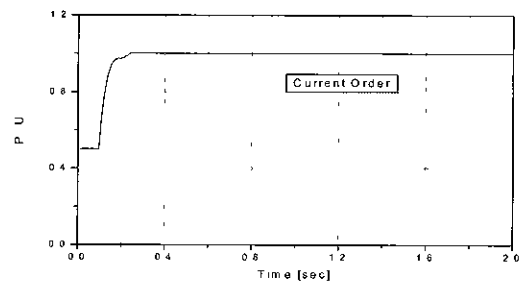
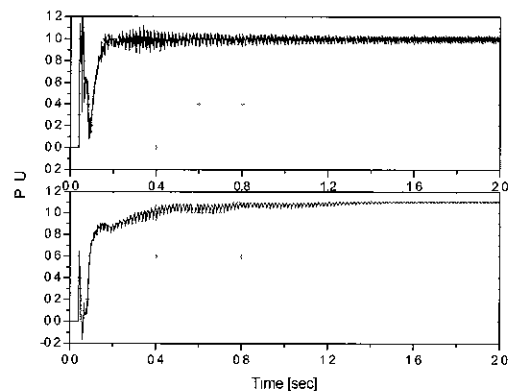

Fig 9 AC system at a rectifier side



(a) Current order in ramp type



(b) Current order in Bang-Bang type

Fig 10 Ramp type's VDCOL

4.1 VDCOL comparison

EMTDC simulation results in Fig 10, Fig. 11 confirm the presence of core saturation instability according to VDCOL (Voltage Dependant Current Order Limit)

However, this method is not the fundamental means to prevent higher harmonic caused by core saturation but only cut off core saturation at the transient state

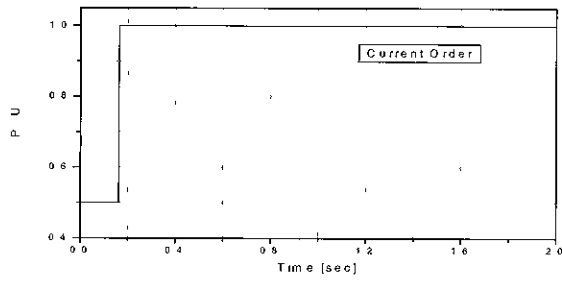

(a) Current order in Bang-Bang type

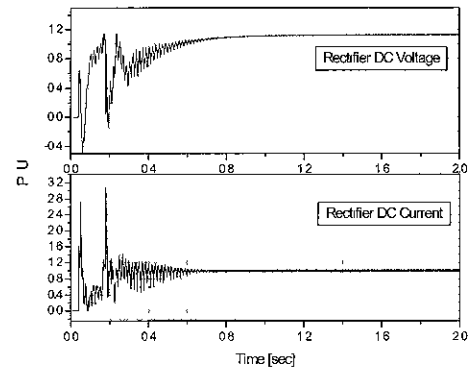

(a) DC current and voltage at current order in Bang-Bang type

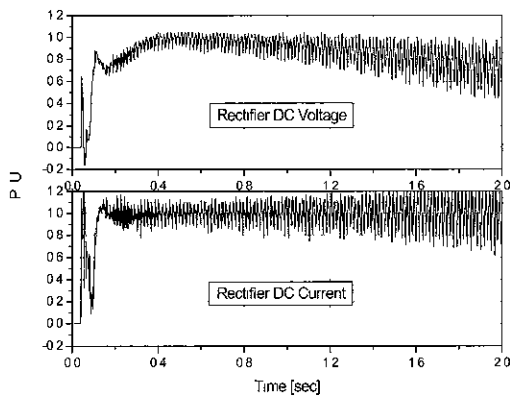

(b) DC current and voltage

Fig 11 Bang-Bang type's VDCOL

4.2 Optimization of current order using Filter

Fig 12 shows that the filter is inserted in current controller not to response 1st harmonic at DC line which generates core saturation. However, it has drawbacks that the response to all of harmonic lags behind, also it must evaluate system performance because of adding to another controller gain.

4.3 Tuned PI gain using Fuzzy function

As shown in Fig 13, the tuned PI gain using Fuzzy function can be implemented by modifying the origin inverter controller of CIGRE HVDC Benchmark in Fig. 8. And parameters of fuzzy controller can be got arbitrarily.

Results of simulation Fig 14 show the robustness and unchangeable characteristics of the controller because of the tuned PI gain using Fuzzy function during transient states of faults and VDCOL in Bang-Bang type.

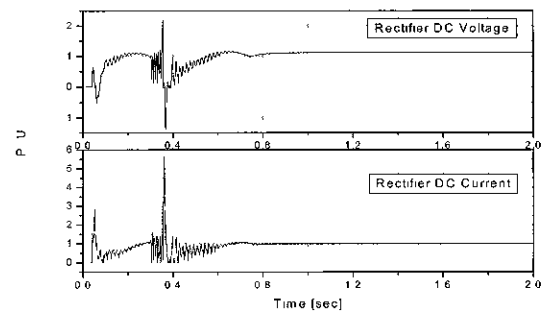

(b) Rectifier's voltage and current at one phase fault

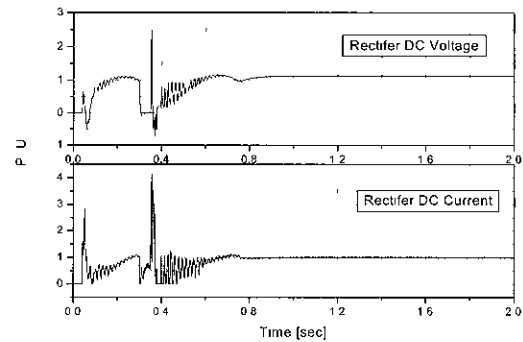

(c) Rectifier's voltage and current at three phases fault

Fig 12 Performance of 60Hz filter in a Bang-Bang type

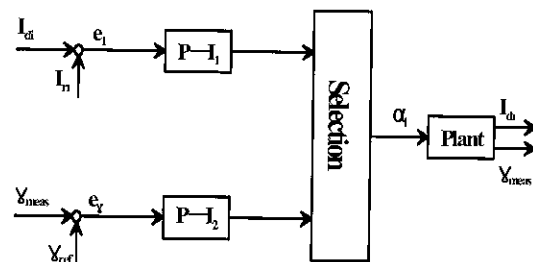

(a) Original Inverter control

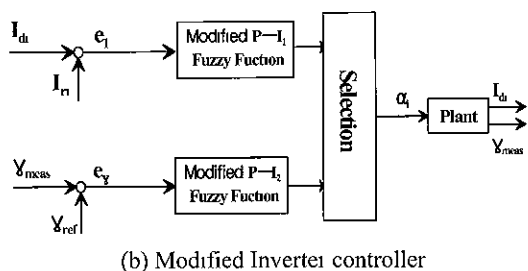

(b) Modified Inverter controller

Fig 13 Inverter's controller of CIGRE HVDC Benchmark model

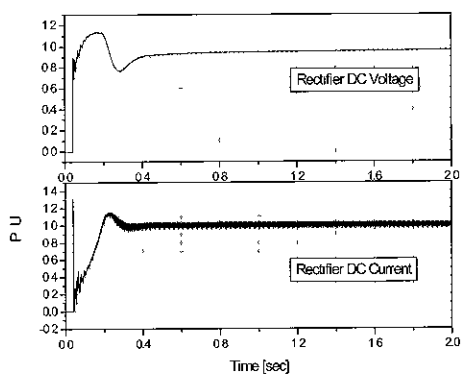

(a) DC current and voltage at current order in Bang-Bang type

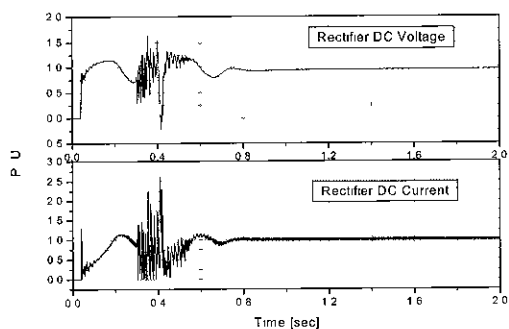

(b) Rectifier's voltage and current at one phase fault

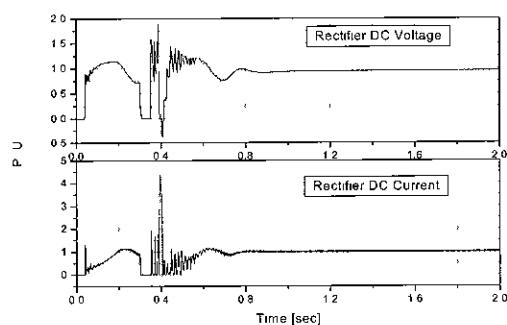

(b) Rectifier's voltage and current at three phases fault

Fig 14 Performance of modified PI gain in a Bang-Bang type

5. Conclusion

This paper has examined the mechanism of converter transformer core saturation instability, indicated the settlement of the problem, and proposed the modified PI controller by means of Fuzzy function to settle the problem of core saturation instability

A DC link can be operated according to the basic control modes and thus remain passive to any special needs of the interconnected AC systems. So, the link can be alternatively provided with more dynamic controls, capable of responding to any deviation from the normal operating condition in the AC or DC systems. And the exclusive use of the basic controls, as like using filters or optimizing the current controller, often gives rise to unwanted interaction between the AC and DC systems, which is manifested in a variety of voltage, harmonic and power instabilities. However, when adopted as the modified PI gain using Fuzzy function that has the advantage of the fast and adaptable converter controllability, a more useful interaction can be achieved and it manifests itself in stable AC and DC system operation, which is confirmed by results of simulations in PSCAD/EMTDC program

References

- [1] S Chen, A R Wood, and J Arrillaga, "HVDC converter transformer core saturation instability a frequency domain analysis", IEE Proc -Gener Transm Distrib, Vol 143, No 1, January 1996
- [2] Taizo Hasegawa, Joukichi Matsushita, Yasushi Oue, Katsuyuki Tomiyama, and Satoru Ihara, "Screening for HVDC System Core Saturation Instability", IEEE Trans on Power Delivery, Vol 15, No 4, October 2000
- [3] R S Burton, C F Fuchshuber, D A Woodford, and A M Gole, "Prediction of core saturation instability at an HVDC converter", IEEE Trans on Power Delivery, Vol 11, No 4, October 1996
- [4] J D Amsworth, "Harmonic Instability Between Controlled Static Converters and AC Networks", Proc IEE Vol 114, No 7, July 1967
- [5] J D Amsworth, "Core Saturation Instability in the Kingsnorth HVDC Link", Paper to CIGRE Study Committee 14, Winnipeg, June 20-24, 1977
- [6] EMTDC User's Manual Manitoba HVDC Research Center, Winnipeg, Manitoba, Canada

- [7] R. Yacamini and J.C. de Oliveira, "Instability in HVDC Schemes at low-order integer harmonics", Proc. IEE, Vol. 127, Pt C, No. 3, 1980.
- [8] High-Voltage direct Current Handbook, First Edition, EPRI.
- [9] GEC Alstom manual: 300MW High Voltage Direct Current Link Between Haenam and Cheju, 1991.



Byeong-Mo Yang was born in Chun-Buk, Korea, on June 09, 1969. He received the B.S., M.S. degree in electrical engineering from Yonsei University. Since 1997, he has worked in KEPRI (KEPCO's research institute). His current research interests are Power Electronics, Power System and HVDC.



Chan-Ki Kim was born in Chung-Buk, Korea, on December 17, 1968. He received the M.S., Ph.D. degree in electrical engineering from Chung-Ang University. Since 1996, he has been with KEPCO, where he is currently a senior researcher and IEEE referee. His current research interests are power electronics, PSS, AVR and HVDC.



Bong-Eon Koh was born in Chun-Buk, on February 28, 1960. He received the B.S degree in electrical engineering from Kwang-Woon University on 1986. He has an HVDC experience as Jeju Converter station manager during three years. His current research interests are Power Electronics, Power System and HVDC.

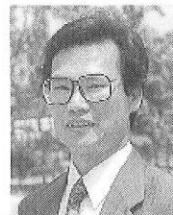

Young Hyun Moon was born in Korea, on March 11, 1952. He received B.S. and M.S. degrees in Electrical Engineering from Seoul National University, and the M.S. and Ph.D. degrees from Oregon State University in 1975, 1978, 1980, and 1983, respectively. In 1983, he joined the faculty of Yonsei University, Seoul, Korea, he is now a professor of electrical Engineering. He visited University of Illinois for the 1992-1993 academic year. Dr. Moon is a member of the IEEE Power Engineering Society. His specialization is state estimation, system control, and stability analysis in electric power system.