

JPE 9-3-18

ICPE'07 Selected Paper

A Hydraulic-Oil Pump System using SR Drive with a Direct Torque Control Scheme

Dong-Hee Lee^{*}, Tae-Hyoung Kim^{*}, and Jin-Woo Ahn[†]

[†]Dept. of Electrical and Mechatronics Engineering, Kyungsoong University, Pusan, Korea

ABSTRACT

The hydraulic-oil pump is widely used for building machinery, brake systems of vehicles and automatic control systems due to its high dynamic force and smooth linear force control performance. This paper presents a novel direct instantaneous pressure control of the hydraulic pump system with SRM drive. The proposed hydraulic pump system embeds the pressure controller and direct instantaneous torque controller. Due to the proportional relationship between pump pressure and torque, pressure can be controlled by the motor torque directly. The proposed direct torque controller can reduce inherent torque ripple of SRM, and develop a smooth torque, which can increase the stability of the hydraulic pump. The proposed hydraulic pump system has also fast step response and load response. The proposed hydraulic pump system is verified by computer simulation and experimental results.

Keywords: Hydraulic-oil pump, SRM, Direct torque control

1. Introduction

The hydraulic pump system is widely used in heavy-duty machines, brake systems of vehicles and automatic control systems of industrial applications^[1-3]. Recently, high efficiency and high performance motor drives for hydraulic pump systems have been in high demand in hydraulic pump systems^[2-3]. SR drive is a good choice for hydraulic pump systems.

The SRM(Switched Reluctance Motors) is investigated for wide industrial applications due to the mechanical strength and cost advantages^[4-6]. SRM has high power-to-weight, torque- to-weight ratios, a wide speed range and excellent

starting characteristics. Therefore, it is suitable for the hydraulic pump system which frequently stops and starts with a full load condition^[6].

Direct torque control scheme has excellent control performance for variable reluctance motor with low torque ripple^[7-12].

This paper presents a novel direct instantaneous pressure control of a hydraulic-oil pump system with SRM drive. The proposed hydraulic pump system embeds the pressure controller and DITC(Direct Instantaneous Torque Control) system^[6-7]. Because of the proportional relationship between pressure and motor torque, the pressure of the hydraulic-oil pump can be controlled by the motor torque directly. A simple PI control scheme is used for pressure control to produce the torque reference. The proposed DITC system can reduce inherent torque ripple of the SRM, and develop smooth torque to load,

Manuscript received February 16, 2009; revised April 9, 2009

[†]Corresponding Author: jwahn@ks.ac.kr

Tel: +81-51-663-4773, Fax:+81-51-663-5980, Kyungsoong Univ.

^{*}Dept. of Electrical and Mechatronics Eng., Kyungsoong Univ. Korea

which can increase stability. The proposed hydraulic pump system has fast step response and load response. In order to verify the proposed control scheme, a 6Mpa hydraulic-oil pump and 2.6kW SR drive are simulated and tested. The computer simulation and experimental results show the effectiveness of the proposed control scheme.

2. A Hydraulic pump system using SR drive

2.1 The Basic Principles of SR Drive and the Hydraulic Pump

Fig. 1 shows the block diagram of a hydraulic oil-pump system using SR drive. As shown in Fig. 1, the pump is operated by the speed and torque controllable SR drive. In order to control the pressure of the pump system, the torque and speed are controlled by the pressure signal, which is fed by the installed sensor.

In a general pressure control of the hydraulic-pump, the PI controller for pressure and torque control and current controller designed by current chopping or PWM method are used.

Fig. 2 shows a general SRM drive system. With a constant phase current, the ideal phase torque is produced according to the square of current and inductance slope of the motor.

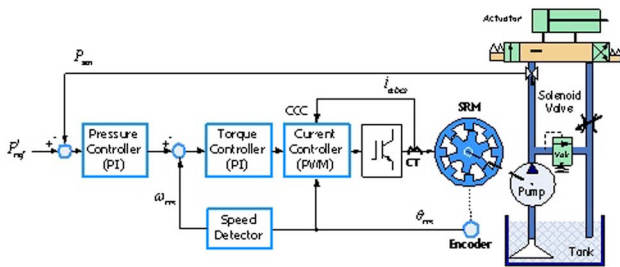

Fig. 1. Block diagram of hydraulic oil-pump system using SR Drive.

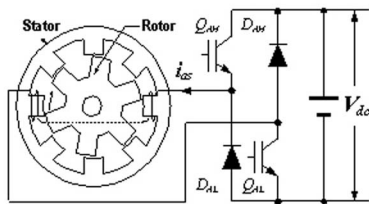

Fig. 2. SRM drive system.

Two basic equations of an SRM can be derived in terms of phase voltage and torque as follows [7-8].

$$v = L_{(\theta_{rm}, i)} \frac{di}{dt} + i \frac{dL_{(\theta_{rm}, i)}}{d\theta_{rm}} \cdot \omega_{rm} \quad (1)$$

$$T_m = \frac{1}{2} \cdot i^2 \cdot \frac{dL_{(\theta_{rm}, i)}}{d\theta_{rm}} \quad (2)$$

where, θ_{rm} : rotor position, ω_{rm} : rotor speed, $L_{(\theta_{rm}, i)}$: inductance according to rotor position and current

For the ideal hydraulic pump, the oil-flow of the hydraulic pump is determined by volumetric displacement and pump speed. In fact, the internal flow leakage in pump and motor should be taken into account by the volumetric efficiency μ_v [2].

$$Q = \mu_v \cdot n_m \cdot V_p \quad (3)$$

where, Q is output flux [m^3 / min], n_m is pump speed [rad/min], V_p is volumetric displacement [m^3/rad].

And the pressure is determined by motor output torque, volumetric displacement and mechanical efficiency μ_m . For pumps pressure is given by:

$$P_p = \mu_m \cdot T_m / V_p \quad (4)$$

where P_p is differential pressure [Pa], T_m is motor output torque [Nm].

2.2 Operating modes of the asymmetric converter

The conventional asymmetric converter is very popular in SR drives, which can provide independent control of each phase and phase overlap. The asymmetric converter has three modes, which are defined as magnetization mode, freewheeling mode and demagnetization mode.

Fig. 3 shows the operating modes of an asymmetric converter. Two power switches and diodes are connected to the motor winding per phase. The asymmetric converter can supply the dc-link voltage in the excitation mode, zero voltage in the free-wheeling mode and negative dc-link voltage in the demagnetization mode as shown in Fig. 3.

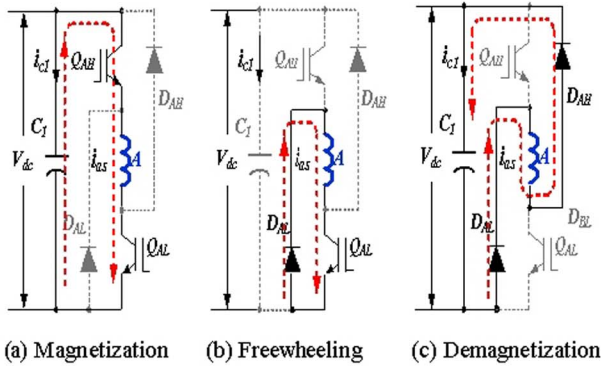

Fig. 3. Operation modes of asymmetric converter.

In the magnetization mode, dc-link voltage is applied to the phase winding. Zero voltage is supplied in the freewheeling mode, and negative dc-link voltage is in the demagnetization mode. Therefore, the voltage states are described as state 1 in magnetization, state 0 in freewheeling mode and state -1 in the demagnetization, respectively.

3. The Proposed Hydraulic Pump System

3.1 DITC Method for SR Drive

In order to eliminate inherent torque ripple of the SR motor, the DITC method is introduced. By the given hysteresis control rules, appropriate torque of each phase can be assigned and constant total torque can be obtained by the proposed DITC method. In this method, the phase inductance has been divided into 3 regions as shown in Fig. 4.

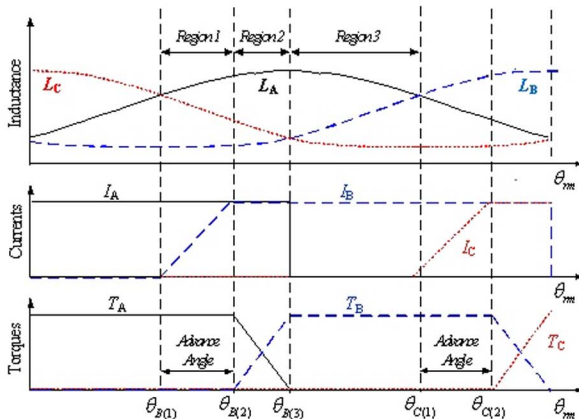

Fig. 4. Principle of DITC method with 3 regions.

The regions depend on the geometrical structure and load level. The boundaries of the 3 regions are $\theta_{B(1)}$, $\theta_{B(2)}$, $\theta_{B(3)}$ and $\theta_{C(1)}$ in Fig. 4. The position of $\theta_{B(1)}$ and $\theta_{C(1)}$ denote the turn-on angles of the phase B and phase C respectively, which depend on load level and operating speed. The $\theta_{B(2)}$ is a rotor position which is the inflexion of inductance in phase B. And $\theta_{B(3)}$ is the aligned point of inductance in phase A. Total length of those regions is 120 electrical degrees in 3 phases SRM. We let the outgoing phase be phase A and the incoming phase is phase B in Fig. 4. When the first 3 regions are over, the outgoing phase will be replaced by phase B in the next 3 regions.

In region 1, the rotor stays in the inductance increasing area of phase A, which remains in the minimum inductance area of phase B. The changing ratio of inductance in phase B is very small. And phase A outputs torque from the motor. At the same time, the excitation current of phase B will be built up easily for the torque in the next region.

In region 2, rotor position gradually approaches maximum inductance of phase A, and variation of the inductance decreases. The output torque of phase A will decrease with rotation of the rotor in this region. Conversely, inductance of phase B goes to an increasing area and the current of phase B has been built up at the end of this region. Because the variation rate of the inductance of phase B is low, phase B cannot develop enough output torque. Therefore, neither of the phases can develop enough instantaneous torque in this region, so phase A and phase B produce enough output torque together. In order to reduce negative torque in the next region, less current of phase A current is desirable. Therefore, the main torque is developed by phase B, and the rest is produced from phase A.

In region 3, inductance of phase A passes the maximum point of the phase inductance and starts to decrease, which produces negative torque. In order to improve efficiency, negative torque of phase A must be reduced. Therefore, the current of phase A drops as soon as possible, which is the best way to cut down negative torque. Magnetization energy is not easy to dissipate in the phase resistor alone. The other way is to return the energy to the DC-link, which can transfer a large part of the field energy to the filter capacitor and reduce phase current quickly. Phase B

enters into an increasing inductance area, and can produce enough torque to overcome the negative torque and satisfy the demands of load.

In order to carry out the DITC method, digital hysteresis control schemes are used. In the proposed DITC method, three control rules are assigned to the 3 regions shown in Fig. 5. The combinatorial states of phase A and phase B are shown as a pane. In order to reduce switching frequency, one switching state is to be changed at a time. It can decrease switching loss of the power devices.

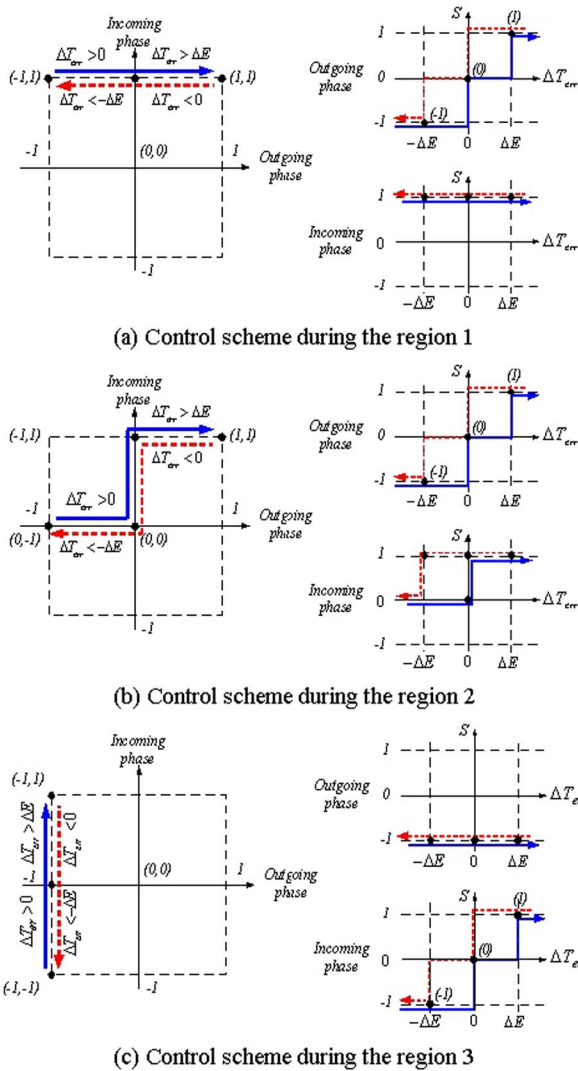

Fig. 5. DITC scheme with an asymmetric converter.

In this figure, x axis denotes the state of phase A, and y axis denotes the state of phase B. Each phase has 3 states, so the pane can have 9 combinatorial states. However,

only the black points of the pane are used in the DITC scheme of each region. The hysteresis rule of phase A and phase B are shown at the right side of pane. The solid line is the incoming phase rule, and the dash line is the outgoing phase rule. The y axis denotes phase state and the x axis denotes torque error between reference and estimated torque. The boundary of torque error is used to change the state of control scheme.

3.2 Advance angle calculation

The incoming phase current should be built-up during region 2 to produce enough torque at the start of region 3. The rising time of the incoming phase current is dependent on the voltage, inductance and motor speed. In order to confirm enough time to build up the excitation current, advance angle is very important. Fig. 6 shows the excitation current according to advance angle. An insufficient advance angle causes insufficient excitation current. An exceed advance angle causes additional loss. As shown in Fig. 6, the motor is excited at θ_{on} position advanced as θ_{adv} from the start point of positive torque region θ_1 to establish a sufficient torque current. The desired phase current is shown as a dash line.

In order to ensure enough time to build up the desired phase current i^* , the advance angle θ_{adv} can be adjusted according to motor speed ω_{rm} and torque command T^* . The desire phase current i^* can be computed by T^* using (2).

$$i^* = \sqrt{\frac{2 \cdot T^* \cdot d \theta_{rm}}{d L(\theta_{rm})}} \tag{5}$$

From the voltage equations of SRM, the proper advance angle can be calculated by the current rising time Δt as follows regardless of phase resistance at θ_1 .

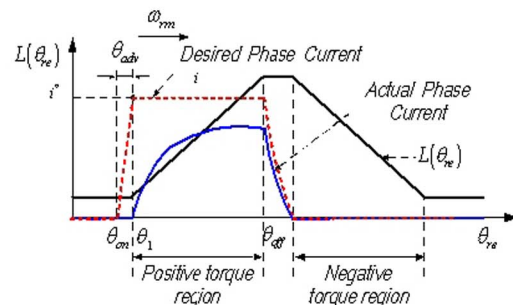

Fig. 6. The build-up of phase current of different θ_{on} .

$$\Delta t = L(\theta_1) \cdot \frac{i^*}{v_{phase}} \tag{6}$$

where, v_{phase} is the terminal voltage of each phase winding. The advance angle is determined by motor speed and Δt as follow:

$$\theta_{adv} = \omega_{rm} \cdot \Delta t \tag{7}$$

When speed increases, the advance angle also needs to increase. At the fixed turn-on position, the actual phase current denoted as a solid line could not reach the desired value to produce sufficient output torque shown in Fig. 6.

3.3 Proposed DITC SR Drive System

Fig. 7 shows the proposed DITC scheme for SR drive.

The torque estimation block is implemented by 3-D lookup table according to the phase currents and rotor position. The digital torque hysteresis controller which carries out the DITC scheme generates the state signals for all activated machine phases according to torque error between the reference torque and estimated torque.

The proper advance angle is calculated by (6) and (7). Then the advance angle of the DITC scheme is updated. The state signal is converted as switching signals by switching the table block to control converter.

Fig. 8 and 9 show the inductance and torque profile of the prototype SRM, respectively. This torque profile is used for torque estimator.

Fig. 10 shows the block diagram of the proposed hydraulic pump pressure control system using the DITC method. A simple PI controller and the proposed DITC are used for pressure control of the hydraulic pump system.

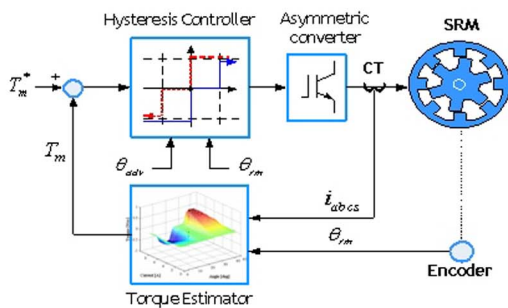

Fig. 7. DITC scheme for SR drive.

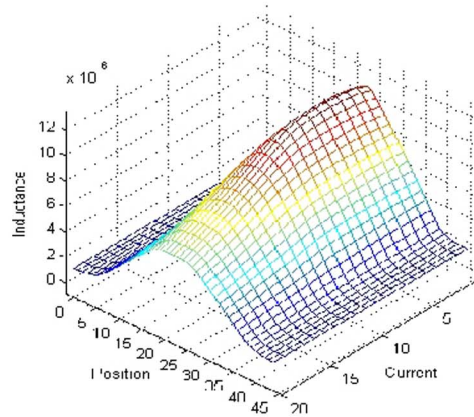

Fig. 8. Inductance profile of the prototype SRM.

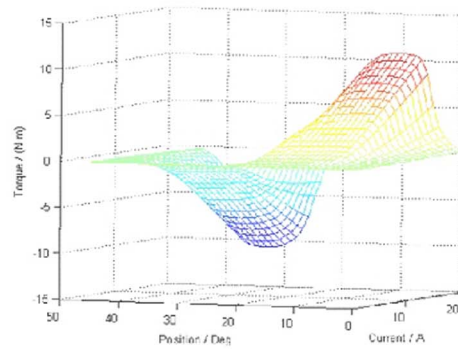

Fig. 9. Torque profile of the prototype SRM.

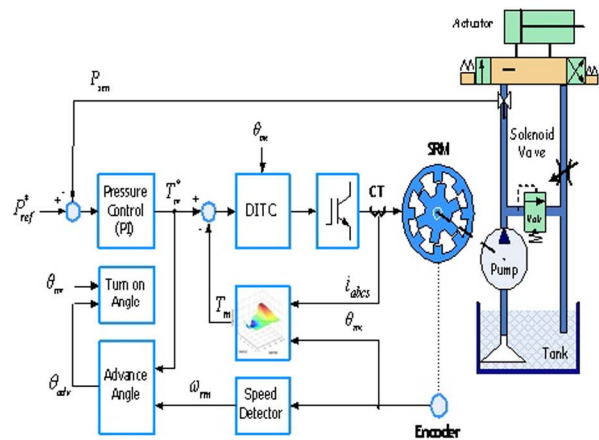

Fig. 10. Proposed hydraulic pump system.

4. Simulation Results

In order to verify the proposed method, some

simulations are executed. The inductance and static torque characteristic of the 2.6kW, 12/8 prototype SRM are analyzed from some experiments and Finite-Element-Method (FEM).

Fig. 11 and Fig. 12 show simulation results between current chopping control (CCC) and the proposed DITC control. The torque ripple of the CCC method is two times higher than the proposed DITC method, and the proposed DITC method obtains smoothing output pressure.

5. Experimental Results

Fig. 13 shows the experimental configuration.

The main controller for the experiments is designed by TMS320F2812 from TI (Texas Instruments) and phase current and voltage signals are feedback to 12bit ADC embedded by DSP. Sampling time of the DITC controller is up to 25 [μs] and sampling time of the pressure controller is 375[μs].

Fig. 14 shows the compared experimental results of conventional CCC and the proposed method at 2[Mpa]. The motor speed is 410[rpm]. The phase current is controlled with a flat-top. However, output torque has a relatively high torque ripple. The smoothing torque during commutation is obtained. The torque ripple is only half of the CCC method.

Fig. 15 shows the load test result of the hydraulic pump system. The hydraulic pump system has an actuator cylinder as load. The cylinder is double acting with the single piston rod, so the extended and retracted operation needs different flux at the same pressure. From Fig. 15, when the cylinder is operated, the hydraulic pump system has quick load response. The response time is less than 100[ms], so the SR motor speed has a fast step response to satisfy the flux requirement.

Fig. 16 shows the experimental result according to pressure reference variation from 2 to 4[Mpa]. According to reference variation, motor current and speed change to maintain the reference value.

Fig. 17 shows the experimental result of load variation at 4[Mpa]. As shown in Fig. 17, the actual pressure is well controlled in sudden load variation.

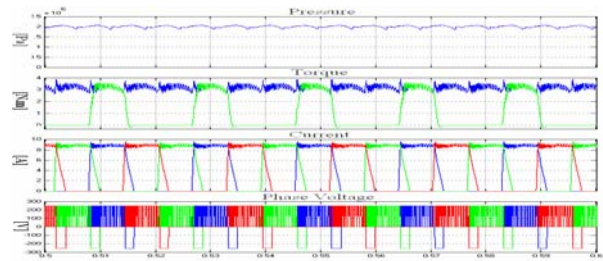

Fig. 11. Current chopping control at 2[MPa].

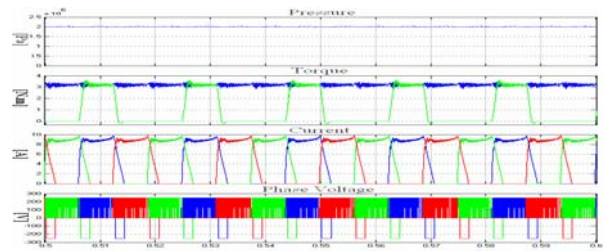
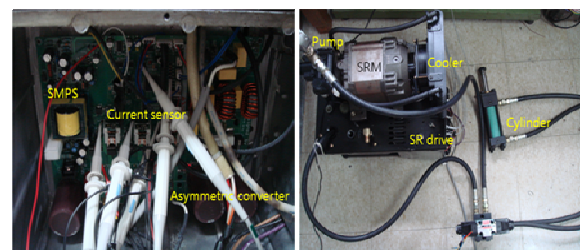
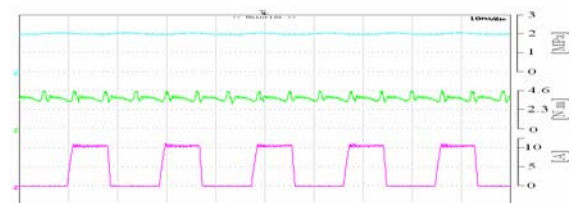

Fig. 12. Proposed DITC control at 2[MPa].



(a) SR drive (b) Hydraulic pump system

Fig. 13. Experimental configuration.



(a) Conventional CCC

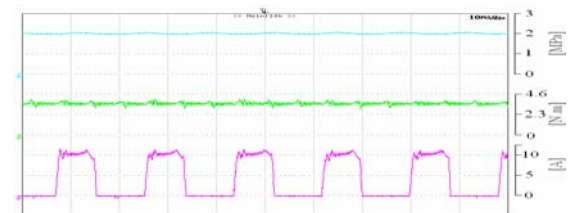

(b) Proposed DITC

Fig. 14. Compared experimental result at 2[MPa].

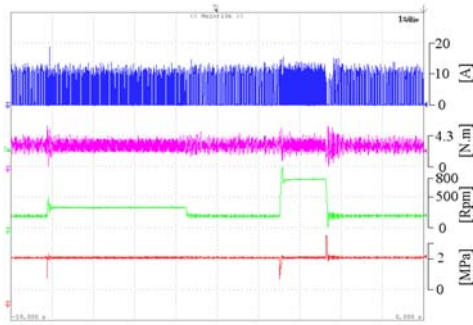

(a) At 2[MPa] cylinder load.

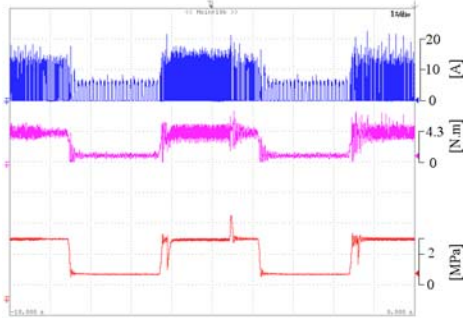

(b) At 3[MPa] cylinder load.

Fig. 15. Operation with cylinder in energy saving mode.

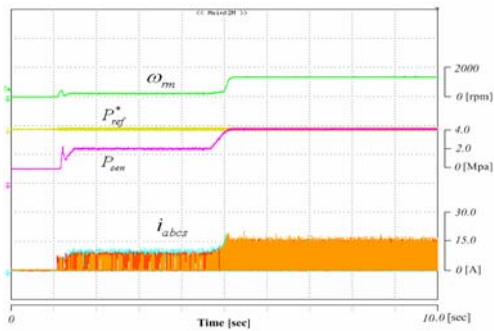

Fig. 16. Pressure change from 2 to 4[Mpa].

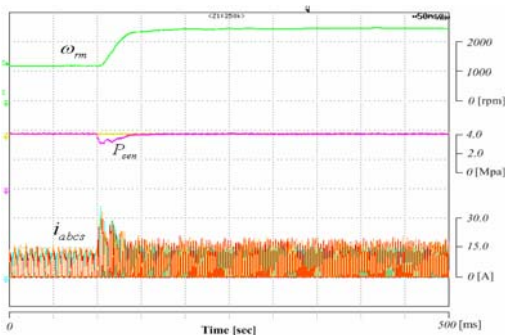

Fig. 17. Load response at 4[Mpa].

6. Conclusion

This paper presents a novel direct instantaneous pressure control of a hydraulic pump system with SRM drive. The proposed hydraulic pump system embeds the pressure controller and DITC controller. The pressure controller is made by a simple PI controller. The DITC controller can reduce inherent torque ripple of SRM and develop smooth torque to the load, which can increase stability.

From the experimental results, the proposed hydraulic pump system operates in a stable manner, and it has fast step response and load response. This proposed hydraulic pump system can embed the energy saving mode, which can improve efficiency of the whole system in operation. Therefore, the proposed hydraulic pump system has high dynamic performance and high efficiency.

Acknowledgment

This work is the outcome of a Manpower Development Program for Energy & Resources supported by the Ministry of Knowledge and Economy (MKE).

References

- [1] J. L. Johnson et al, Introduction to Fluid Power, Science & Technology, 2004.
- [2] Peter Chapple, "Principles of Hydraulic System design," Coxmoor Publishing Company, 2003.
- [3] Du, Hongliu, "An E/H Displacement and Power Control Design for Hydraulic Variable Displacement Pumps," in the Proceedings of the ASME International Mechanical Engineering Congress and Exposition, New York, NY, Nov. 2001.
- [4] J. W. Ahn, "Switched Reluctance Motor", Osung Media, 2004.
- [5] J.F. Gieras, J.H Choi, "Design of High-Speed High Power Switched Reluctance motor," *Journal of Power Electronics*, Vol. 1, No. 1, pp.19-25, 2001.
- [6] B.C. Kim, D.H. Lee, J.W. Ahn, "Performance of SR drive for hydraulic pump," *Proceedings of ICEMS 2005*, Vol.1, pp.659 - 663, 27-29, Sept. 2005.
- [7] J. Liang, Z. G. Lee, D. H. Lee, J. W. Ahn, " DITC of SRM Drive System Using 4-Level Converter," *Proceedings of ICEMS 2006*, Vol. 1, pp. 21-23, Nov. 2006.

- [8] Inderka, R.B., De Doncker, R.W., "DITC-direct instantaneous torque control of switched reluctance drives," 37th IAS Annual Meeting. Vol. 3, pp. 1605 – 1609, Oct. 2002.
- [9] R. C. Kavanagh, J. M. D. Murphy, and M. G. Egan, "Torque ripple minimization in switched reluctance drives using self-learning techniques," in *Proc. IEEE-IECON Conf. Rec. '91*, pp. 289-294, 1991.
- [10] D. S. Schramm, B. W. Williams, and T. C. Green, "Torque ripple reduction of switched reluctance motors by phase current optimal profiling," in *Proc. IEEE-PESC Conf. Rec. '92*, pp. 857-860, 1992.
- [11] J. C. Moreira, "Torque ripple minimization in switched reluctance motors via bi-cubic spline interpolation", in *Proc. IEEE-PESC Conf. Rec. '92*, pp. 851-856, 1992.
- [12] M.H. Kim, "Direct Torque Control System of a Reluctance Synchronous Motor Using a Neural Network," *Journal of Power Electronics*, Vol. 5, No. 1, pp.36-44, 2005.



Dong-Hee Lee was born on Nov. 11, 1970 and received B.S, M.S., and Ph. D degrees in Electrical Engineering from Pusan National University, Pusan, Korea, in 1996, 1998 and 2001, respectively. He worked as a Senior Researcher of Servo R&D Team at OTIS-LG, from 2002 to 2005. He has been with Kyungsoong University, Pusan, Korea, as an Assistant professor in the Department of Electrical and Mechatronics Engineering since 2005. His major research field is the Servo System and Electrical Motor Drive with Power Electronics.



Tae-Hyoung Kim was born in Andong, Korea, in 1977. He received B.S, M.S. degrees in Electrical Engineering from Kyungsoong University, Pusan, Korea, in 2003 and 2005. He is currently working toward the Ph.D degree in Kyungsoong University. His current research interests are advanced motor drive system and motor design.



Jin-Woo Ahn was born in Busan, Korea, in 1958. He received the B.S., M.S., and Ph.D. degree in Electrical Engineering from Pusan National University, Pusan, Korea, in 1984, 1986, and 1992, respectively.

He has been with Kyungsoong University, Busan, Korea, as a professor in the Department of Electrical and Mechatronics Engineering since 1992. He was a visiting researcher in Speed Lab, Glasgow University, U.K., a visiting professor in the Dept. of ECE and WEMPEC, UW-Madison, USA, and a visiting professor in the Dept. of ECE, Virginia Tech from July 2006 for a year. He is a director of Advance Electric Machinery and Power Electronics Center since 2005. He is also director of Smart Mechatronics Advanced Research and Training Center from August 2008 and Senior Easy Life Regional Innovation System from July 2008, which are overseen by the Ministry of Knowledge Economy, Korea. He is the author of five books including SRM, the author of more than 100 papers, and has several patents. His current research interests are advanced motor drive systems and electric vehicle drive. Dr. Ahn received several paper awards including the Best Paper Award from the Korean Institute of Electrical Engineers and the Korean Federation of Science and Technology Society in 2003, respectively. He is a senior member of Korean Institute of Electrical Engineers, a member of Korean Institute of Power Electronics and a senior member of IEEE.