

Simulator for Monitoring the Operations of Range Extender Electric Vehicles

Tae-Won Chun[†], Quang-Vinh Tran^{*}, Hong-Hee Lee^{**}, Heung-Geun Kim^{***}, and Eui-Cheol Nho[‡]

^{†**} Dept. of Electrical Eng., University of Ulsan, Ulsan, Korea

^{*} ENLAKA Co., Hochiminh, Vietnam

^{***} Dept. of Electrical Eng., Kyungpook National University, Daegu, Korea

[‡] Dept. of Electrical Eng., Pukyong National University, Busan, Korea

Abstract

In this paper, the simulator of an on-line monitoring system for the range extender electric vehicle has been developed. The messages from the four control modules, the air pressure and fuel level sensors data, and the on/off switching states of 31 indicator lamps can be received through the control area network (CAN), and displayed on the graphic panel. The simulator was designed using the four DSP boards, variable resistors, and toggle switches instead of the four control modules, sensors, and switching state of indicator lamps on an actual series hybrid electric vehicle (SHEV) bus, respectively. The performance of the monitoring technologies was verified with the simulator at the laboratory, and then it was tested on an actual SHEV bus. The simulator is very useful at the initial development of the monitoring system at the hybrid-type or electrical vehicles.

Key Words: CAN, Monitoring, Range extender, Series hybrid electric vehicle (SHEV) bus, Simulator

I. INTRODUCTION

The battery-power electric vehicles possess some advantages over conventional internal combustion engine (ICE) vehicles, such as high energy efficiency and zero environmental pollution. However, the operation range per battery charge is far less competitive than that of ICE vehicles, due to the low energy content of the batteries. The hybrid electric vehicles (HEVs) which are powered by both an electric motor and an ICE, reduce emission and increase the fuel efficiency of the vehicles. The HEV can be classified into two types : series hybrid and parallel hybrid.

The drawbacks of the series HEV (SHEV) over parallel types are the requirements of two electrical machines and the large dimensions required for the traction motor, in addition to the losses incurred during the conversion of mechanical to electrical energy. On the other hand, the engine attached to an electric generator provides a highly efficient source of energy to charge the vehicle battery. The engine is fully decoupled from the driven wheel and can operate at the most optimum region of the engine power-speed characteristics [1], [2]. The series hybrid system is easier to build and does not require a transmission. In case of the heavy duty vehicles such as a

bus, the SHEV is more suitable for the frequent stop-and-go driving at urban routine. A growing number of companies are developing and beginning to supply commercial series hybrid-electric drive products to the bus markets.

The driving range can be extended using an ICE to turn a generator and recharge the vehicle batteries. Therefore, the SHEV is suited for use in a range extender EV. The control design methods of an optimized ICE fueled by the hydrogen or gasoline in a series-hybrid power-train configuration for the driving range extender are suggested [3]–[5]. The power flow management algorithm for the SHEV composed of the engine-generator and battery bank in order to satisfy the required power for the propulsion system while keeping fuel consumption and vehicle emissions as low as possible is presented [6]–[9]. In the exiting papers related to SHEVs, studies are mostly concentrated on designing the optimal energy management strategies with the consideration of the battery state-of-charge (SOC).

The monitoring technologies are necessary for the optimal operation of the power-train in the SHEV and timely detection of abnormal conditions during the initial development of hybrid technologies to preclude lack of knowledge from causing program failure. However, the monitoring systems at the EV are only applied to estimate the SOC of the battery pack by monitoring the battery voltage, current and temperature through the network [10], [11].

This paper develops the simulator of the on-line monitoring system for the control area network (CAN) messages communicated with control modules in the SHEV bus. In addition,

Manuscript received Dec. 29, 2010; revised Mar. 21, 2011

Recommended for publication by Guest Associate Editor Byoung-Kuk Lee.

[†] Corresponding Author: twchun@mail.ulsan.ac.kr

Tel: +82-52-259-2181, Fax: +82-52-259-1686, University of Ulsan

^{*} ENLAKA Co., Vietnam

^{**} Dept. of Electrical Eng., University of Ulsan, Korea

^{***} Dept. of Electrical Eng., Kyungpook National University, Korea

[‡] Dept. of Electrical Eng., Pukyong National University, Korea

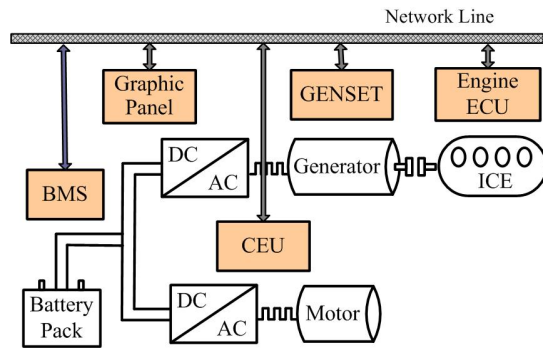

Fig. 1. Communication schematic of SHEV bus.

bit	D28-D26	D25	D24	D23-D16	D15-D8	D7-D0
Field	Priority	R	DP	PDU Format	PDU Specific	Source Address

Fig. 2. Structure of the 29-bit identifier.

it can indicate all sensor gauges and the operating state of a set of indicator lamps. The performance of the monitoring system can be easily investigated by using the simulator before applying it to the actual range extender EV bus. It can save both the cost and time on development.

II. NETWORK STRUCTURE

A. Structure of the SHEV Bus

In the SHEV, many electrical modules are functionally interconnected as shown in Fig. 1. In this scheme, the ICE power controlled by an engine control unit (ECU) is converted to dc electric power with the help of an ac generator, ac-to-dc converter, and generator set unit (GENSET).

The battery power is fed to an induction motor through a dc-to-ac converter controlled by a control electronics unit (CEU), which drives the wheels. The vehicle's battery pack consists of 28 lead-acid batteries with a nominal voltage of 12V connected in series. The charge/discharge strategy for the battery pack is accomplished via the battery management system (BMS). The four control modules are connected through the CAN bus for communicating their messages. A graphic panel is used to monitor the CAN messages received from the four modules, and indicate additionally all sensor gauges and the switching state of a set of indicator lamps.

B. Data Messages in SHEV Bus

The CAN is used for real-time communication between the four control modules and a host DSP. The CAN was originally developed to support low cost simple automotive applications, because of its performances and economic feasibility [13], [14]. The J1939 is specified as the CAN protocol, designed to support real-time control functions between electronic control devices which may be distributed throughout the heavy-duty vehicle such as the buses and trucks. Most messages defined by the J1939 standard are intended to be broadcast. The J1939 uses a 29-bit identifier defined within the CAN 2.0B protocol, as shown in Fig. 2.

The first three bits of the identifier are used for controlling a message's priority during the arbitration process. At the

TABLE I
MESSAGES OF THE CONTROL MODULES

Module	Messages
CEU	<ul style="list-style-type: none"> . Operation status and fault information . High battery input voltage and current . Speed, input current, and temperature of motor . Input voltage, current, and temperature of charger
GENSET	<ul style="list-style-type: none"> . Operation status and fault information . Speed and temperature of generator . Power and coldplate temperature of GENSET
BMS	<ul style="list-style-type: none"> . Operation status and fault information . SOC of battery pack . Highest and lowest battery cell number and voltage . Battery pack output voltage and current . Hottest and coolest cell number and temperature . Average voltage and temperature of battery cell
Engine ECU	<ul style="list-style-type: none"> . Temperature and pressure of engine oil . Temperatures of engine coolant and fuel . Pressure and temperature of intake air

SHEV bus, all messages of the four control modules have the identical priority. The next bit of the identifier is reserved for future use and should be set to a value of zero (0) for transmitted messages. The next bit in the identifier is the data page selector. This bit expands the number of possible Parameter Groups that can be represented by the identifier.

The PDU format (PF) determines whether the message can be transmitted with a destination address or the message is always transmitted as a broadcast message. As the message can only be broadcast if the PF is between 240 and 255, the field PF of four control modules in the SHEV is determined as 255 or 254 for broadcast messages. The PDU specific (PS) field is used as a message number. Thus, the PS fields of 13 messages of CEU, GENSET, and BMS modules are determined to the range from 0 to 12, and the PS fields of the three messages of the engine ECU are assigned as 238, 239, and 246.

The contents of the messages of each control module are shown in Table I, where some useful data can only be received from the engine ECU, as the engine ECU has many messages. The data transmission rate of the J1939 is 250kbps, and a typical message containing eight data bytes and 29 bit identifier is 128 bits long. The four control modules transmit their messages independently to a CAN network on every 100msec or 200msec. The monitoring system receives the messages through the CAN, and then displays the data in the messages on the graphic panel.

III. SENSOR GAUGES AND INDICATOR LAMPS

The monitoring system indicates the front/rear brake air pressure gauges, fuel level gauge, oil pressure gauge, and switching state for 31 indicator lamps located on the dashboard display in a conventional bus.

A. Sensor Gauges

Fig. 3 shows the characteristics of a front/rear air brake pressure sensor whose resistance varies as a function of the air pressure. As the air pressure may be varied from 0 to 12[Kg/cm²], the sensor resistance is changed from 0[Ω] to 230[Ω]. So, the sensor has a positive pressure coefficient. The span of the needle angle of an air pressure gauge is 90°.

The characteristics of the fuel level sensor with a negative level coefficient is provided in Fig. 4. As the diesel fuel level

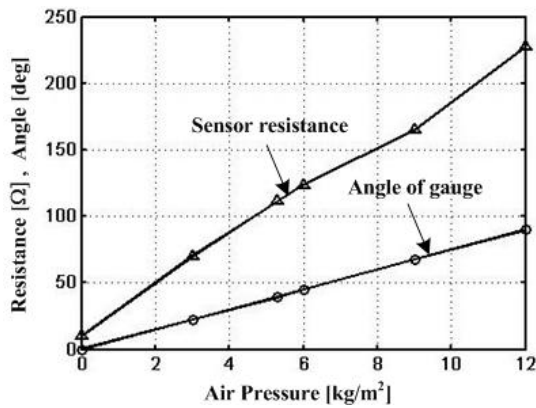

Fig. 3. Characteristics of the air brake pressure sensor and gauge.

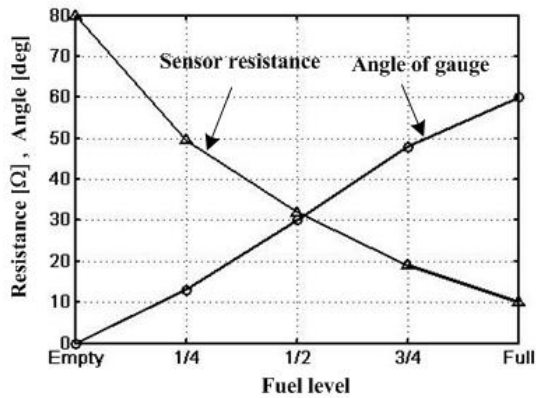

Fig. 4. Characteristics of the fuel level sensor and gauge.

is higher, the sensor resistance is decreased from 80[Ω] to 10[Ω]. The span of the needle angle of the fuel level gauge is 60°. The values of both sensors are indicated by points which the needle revolves around within a circular gauge.

The measurement circuit for both sensors is shown in Fig. 5. A pull-up resistor is connected in series to the sensor. After amplifying an analog measured signal taken from the midpoint lying between the resistor and the sensor, it is sent to the 12-bit analog/digital converter embedded in the DSP. The resistance of the sensors is converted into a digital value using the measurement circuit and A/D converter, and the pin points of needle in the circular gauge are calculated by using a curve fitting function of the Matlab program.

Fig. 6(a) and (b) show the real and fitted angles at the circular gauge as a function of the digital value of the A/D converter for both sensors, respectively. It can be seen that the fitted angle is nearly the same as the real angle for both sensors. The oil pressure gauge is adjusted by the data received from the engine ECU through CAN.

B. Indicator Lamps

The indicator system is used to communicate the driver's intentions to the external environment around the vehicle and generate various warning signals compatible with the operating situations and conditions of the SHEV bus. At the SHEV bus, 31 indicator signals are available, and the monitoring system can indicate on/off state for all indicator lamps. The indicator signals are of two types: active-high signals, active-

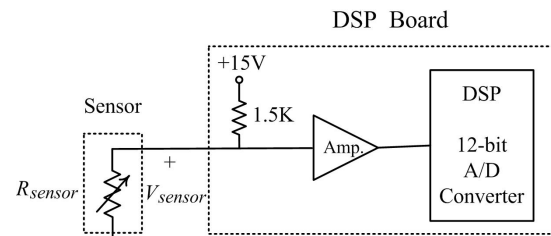
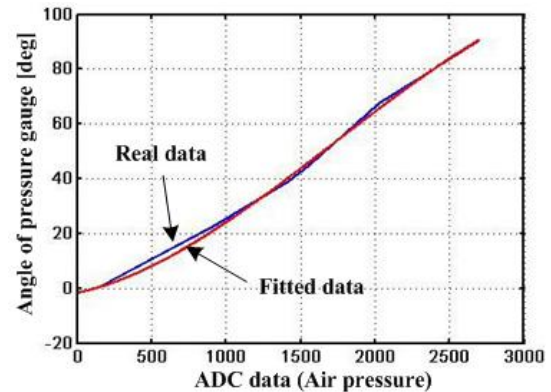
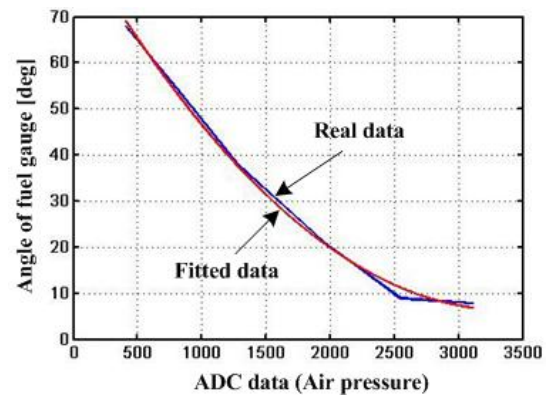

Fig. 5. Measurement circuit of sensor data.



(a)



(b)

Fig. 6. Angle of a circular gauge to ADC data. (a) Air pressure sensor, (b) fuel level sensor.

low signals. The circuit for measuring indicator signals of both types is shown in Fig. 7.

When the control signal is activated at the measurement circuit for an active-high signal as shown in Fig. 7(a), the output terminal voltage becomes +24V, which is an auxiliary battery voltage. The voltage level of the signals must be reduced to 3.3V with the voltage divider, and then the on/off state of indicator lamps can be read through the I/O ports in the DSP. At the measurement circuit for the active-low signal as shown in Fig. 7(b), the switch terminal is tied to +3.3V through a pull-up resistor for limiting the voltage level to 3.3V.

The toggle switch is used at the simulator instead of a magnetic relay, the switching state of which is controlled by a control signal. As the SHEV has 21 active-high indicator signals and 10 active-low signals, the simulator has 31 toggle switches.

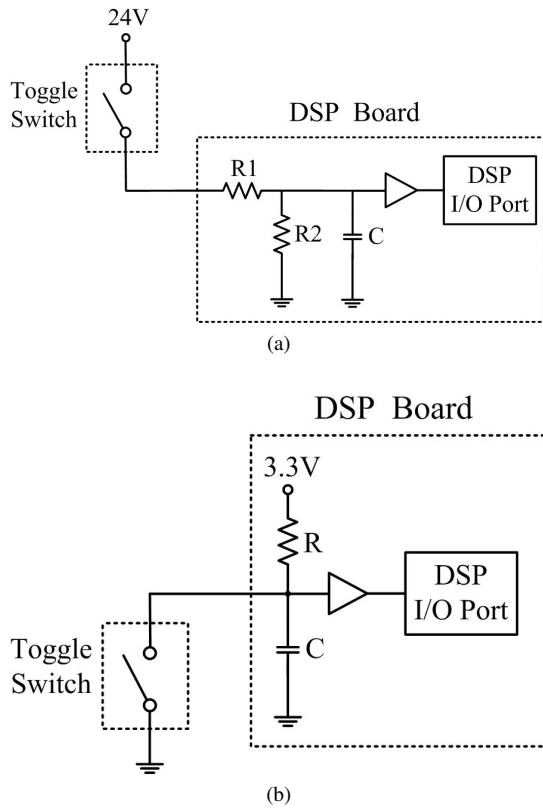

Fig. 7. Measurement circuit of the indicator signals. (a) Active-high signal, (b) active-low signal.

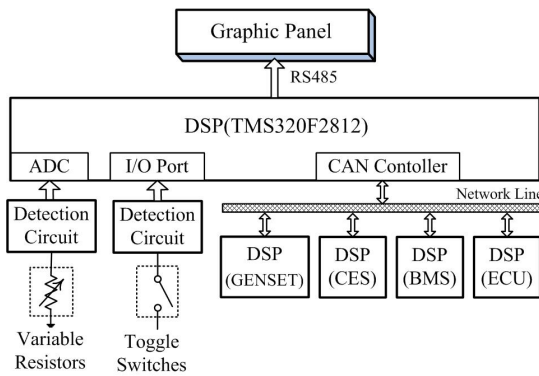

Fig. 8. Hardware configuration of the simulator.

IV. CONFIGURATION OF THE SIMULATOR

A simulator for the monitoring system is implemented by 32-bit DSP type TMS320F2812 operating with a clock frequency of 150MHz. It provides the 16 channels 12-bit A/D converter, 56 general purpose I/O pins, CAN 2.0B controller, flash memory, and so on. Fig. 8 shows the hardware configuration of the simulator using the 32-bit DSP. The variable resistors are used at the simulator for adjusting the sensor data instead of the actual sensors, and the toggle switches are used for changing the on/off state, instead of a magnetic relay. The four DSP boards act as four control modules, where each DSP board transmit the same messages as its control module to the CAN bus.

The host DSP receives data through the CAN controller, A/D converter, and I/O port and transmits the data sequentially to the graphic panel through an RS-485 serial port. The

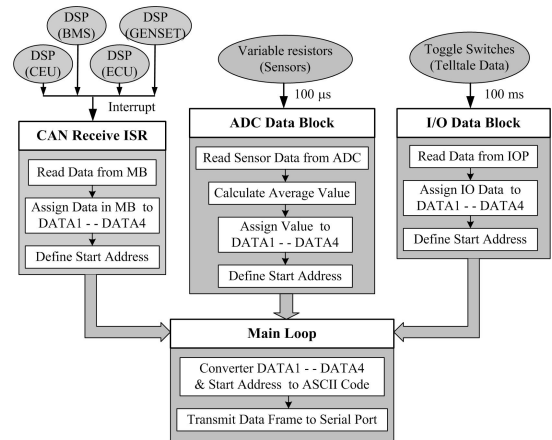

Fig. 9. Flowchart of the system software.

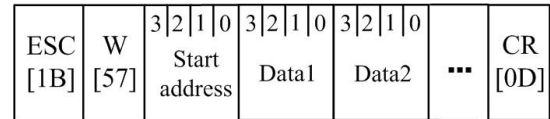

Fig. 10. Structure of the data frame.

flowchart of the system software is shown in Fig. 9. Whenever a CAN receiver interrupt is generated, the message can be received from the control modules. The measured values of the variable resistors acted as the front/rear air brake sensors and the fuel level sensor are received through the A/D converter on every 100usec. The pin points of the needles in the circular gauges are calculated, where the average value of measured sensor data for two seconds is used for avoiding the rapid oscillation of needles. The on/off switching states of the toggle switches can be obtained from I/O ports on every 100msec.

The packages are constructed with the data frame structure required from a graphic panel as shown in Fig. 10. The structure of the data frame at the graphic panel is as follows.

- ‘ESC’ : Start of frame code
- ‘W’ : Write command for transmitting data
- Start address : Buffer address for storing data
- Data : Transmitting data
- ‘CR’ : End of frame code

They are sequentially transmitted to the graphic panel for monitoring the operations of the SHEV bus through an RS-485 serial port. The baud rate of the serial communication is 196,000bps, and each package contains 6- or 8-byte data length.

V. TESTING RESULTS FOR THE SHEV BUS

Fig. 11 shows the photograph of the simulator, which consists of the host DSP board, four DSP boards, 31 toggle switches, three variable resistors for the front/rear brake air pressure sensors and fuel level sensor, and the graphic panel.

Fig. 12 shows the main screen of the graphic panel, which indicates four gauges (front/rear brake air gauges, fuel level gauge, and engine oil pressure gauge), on/off states of all indicator lamps, vehicle speed, and SOC of the battery pack. There are four icons at the bottom section of the main screen. Three icons such as CEU, BMS, GENSET/ECU are used for monitoring the data of the messages received from the four control modules.

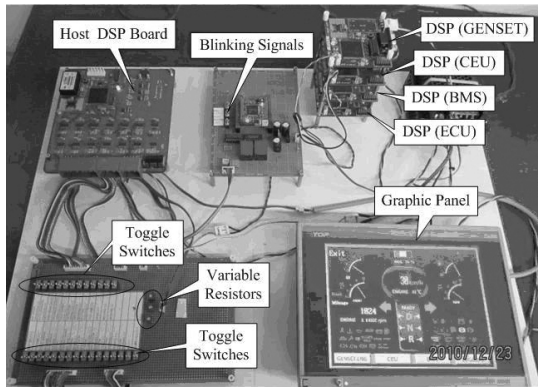

Fig. 11. Photograph of the simulator.



Fig. 12. Main screen of the graphic panel.

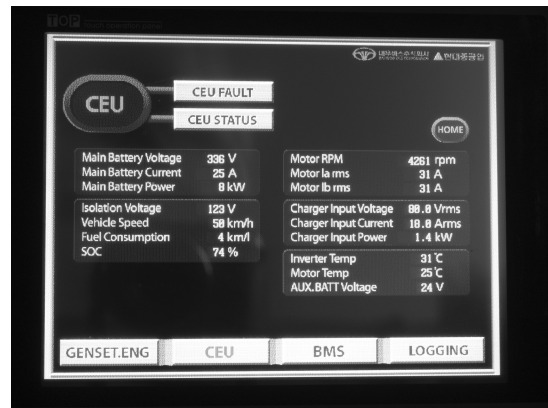

Fig. 13. Screen for CEU module.



Fig. 14. Screen for BMS module.

Fig. 13 shows the CEU screen of the graphic panel when the ‘CEU’ menu is selected. The battery voltage/ current/power, motor speed/current, charger input voltage/current/power, temperatures of the motor drive system, and fault/status conditions of the CEU can be investigated.

Fig. 14 shows the BMS screen, where the power/current/voltage of the battery pack, average/maximum/ minimum of the battery voltage, average/maximum/minimum of the battery temperature can be monitored. Also shown is which battery has the minimum voltage or maximum voltage.

Fig. 15 shows the GENSET/ECU screen, where the fault conditions, operating status, and various parameters in both the GENSET and Engine ECU modules can be investigated. A menu ‘LOGGING’ is used to record some parameters for a long time for investigation.

After the performance of the monitoring system of the range extender EV bus is verified with the simulator at the laboratory, it is mounted and tested on an actual SHEV bus made by the Hyundai Heavy Industries Company as shown in Fig. 16.

VI. CONCLUSIONS

In this paper, the simulator of the on-line monitoring system for the range extender EV bus has been developed. The simulator was designed using the four DSP boards, variable resistors, and toggle switches instead of the four control modules, sensors, and switching state of indicator lamps at the SHEV bus, respectively. At the simulator, the messages from the four DSP boards (GENSET, CEU, BMS, and Engine ECU), data of three sensors, and the on/off switching states

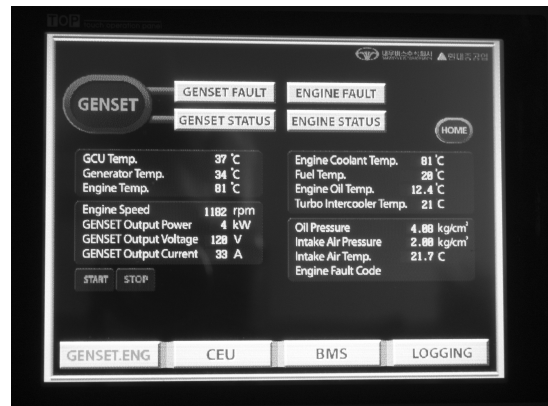

Fig. 15. Screen for the GENSET and ECU modules.



Fig. 16. Monitoring system on an actual SHEV bus.

of 31 toggle switches can be received through the CAN, and displayed on the touch panel. After the performance of the monitoring system of the range extender EV bus was verified with the simulator at the laboratory, it was mounted and tested on an actual SHEV bus. The simulator is very useful at the initial development of the monitoring system at the hybrid-type or electrical vehicles, because it is easy to investigate and revise abnormal operation of the monitoring system.

ACKNOWLEDGMENT

This work was supported by the Power Generation & Electricity Delivery of the Korea Institute of Energy Technology Evaluation and Planning (KETEP) grant funded by the Korea government Ministry of Knowledge Economy (No. 2010T100100465)

REFERENCES

- [1] C. C. Chan, "The state of the art of electric, hybrid, and fuel cell vehicles," in *Proc. the IEEE*, Vol. 95, No. 4, pp. 704-718, Apr. 2007.
- [2] M. Ehsani, Y. Gao, and A. Emadi, *Modern Electric Hybrid Electric and Fuel Cell Vehicle-Fundamentals, Theory, and Design*, CRC, 2005.
- [3] M. V. Wieringen and R. P. Lliev, "Development of a dual-fuel power generation system for an extended range plug-in hybrid electric vehicle," *IEEE Trans. Ind. Electron.*, Vol. 57, No. 2, pp. 641-648, Feb. 2010.
- [4] A. S. Al-Adsni, A. M. Jarushi, and N. Schofield, "An ICE/HPM generator range extender in a series hybrid electric vehicle," in *Proc. PEMD*, pp. 1-6, 2010.
- [5] F. Yunzhou, Z. Han, P. Qingfeng, and L. Shijiang, "Research on generator set control of range extender pure electric vehicles" in *Proc. IEEE-APPEEC*, pp. 1-4, 2010.
- [6] M. V. Wieringen and M. Bernacki, and R. P. Lliev, "Design and development of plug-in-by-wire(less) hydrogen internal combustion engine extended range electric vehicle," in *Proc. IEEE-VPPC*, pp. 1-8, 2008.
- [7] X. Liu, Q. Fan, K. Zheng, J. Duan, and Y. Wang, "Constant SOC control of a series hybrid electric vehicle with long driving range," in *Proc. IEEE-ICIA*, pp. 1603-1608, 2010.
- [8] M. Gokasan, S. Bogosyan, and D. J. Goering, "Sliding mode based powertrain control for efficiency improvement in series hybrid-electric vehicle," *IEEE Trans. Power Electron.*, Vol. 21, No. 3, pp. 779-790, May 2006.
- [9] S. Barsali, M. Ceraolo, and A. Possenti, "Technique to control the electricity generation in a series hybrid electrical vehicle," *IEEE Trans. Energy Conv.*, Vol. 17, No. 2, pp. 260-266, Jun. 2002.
- [10] J. T. B. A. Kessels, M. W. T. Koot, P. P. J. Bosch, and D. B. Kok, "Online Energy management for hybrid electric vehicles," *IEEE Trans. Veh. Technol.*, Vol. 57, No. 6, pp. 3428-3430, Nov. 2006.
- [11] R.-G. Lu, L. Pei, R. Ma, J.-L. Wei, and C.-B. Zhu, "EV energy storage monitoring system based on distributed data acquisition," in *Proc. IEEE-VPPC*, pp. 1386-1389, 2009.
- [12] M. Silva, J. P. Trovao, P. Pereira, L. Marques, "Multiple energy sources monitoring system for electric vehicle," in *Proc. IEEE-SPEEDAM*, pp. 750-755, 2008.
- [13] R. V. Chacko, Z. V. Lakaparampil, and V. Chandrasekar, "CAN based distributed real time controller implementation for hybrid electric vehicle," in *Proc. IEEE-IECON*, pp. 247-251, 2005.
- [14] B. J. Ahn, B. R. Park, Y. H. Ki, H. S. Ahn, and D. H. Kim, "Development of a controller area network unit and its application to a fuel cell hybrid electric vehicle," in *Int. Joint Conf. of SICE-ICASE*, pp. 5545-5549, 2006.



Tae-Won Chun was born in Korea in 1959. He received the B.S. degree in Electrical Engineering from Pusan National University, Korea, in 1981, and received the M.S. and Ph.D. degrees in Electrical Engineering from Seoul National University, Korea, in 1983 and 1987, respectively. Since 1986, he has been a member of the faculty of the Department of Electrical Engineering, Ulsan University, Korea, where he is currently a full Professor. From 1996 to 1997, he was with the Department of Electrical and Computer Engineering, University of Tennessee, USA as a visiting scholar. From 2005 to 2006, he also served as a visiting

scholar with the Department of Electrical and Computer Engineering, Virginia Polytechnic Institute and State University, USA. His current research interests are the control of electrical machines and power conditioning systems.



Quang-Vinh Tran was born in Vietnam in 1979. He received the B.S. degree in electronics and electrical engineering from Hochiminh University of Technology in 2002. From 2002 to 2004, he was with Hochiminh city Power Company at Vietnam. He received the M.S. and Ph.D. degrees in electrical engineering from University of Ulsan, Korea, in 2006 and 2010, respectively. He is currently the researcher in ENLEKA Company at Vietnam. His current research interest is the design of ZSI, and PV generation system.



Hong-Hee Lee was born in Korea in 1957. He received the B.S., M.S. and Ph.D. degrees in Electrical Engineering from Seoul National University, Korea, in 1980, 1982 and 1990, respectively. Since 1985, he has been a member of the faculty of the Department of Electrical Engineering, Ulsan University, Korea, where he is currently a full Professor. He was with the Department of Electrical Engineering, University of Texas A&M, USA as a visiting scholar from 1990 to 1991. His current research interests are the wind power generation, matrix converters, and network-based factory automations.



Heung-Gun Kim was born in Korea in 1956. He received the B.S., M.S. and Ph.D. degrees in Electrical Engineering from Seoul National University, Korea, in 1980, 1982 and 1988, respectively. Since 1984, he has been a member of the faculty in the Department of Electrical Engineering, Kyungpook University, Korea, where he is currently a full Professor. He was with the Department of Electrical Engineering, University of Wisconsin-Madison, USA, as a visiting scholar from 1990 to 1991. From 2006 to 2007, he also served as a visiting scholar with the Department of Electrical and Computer Engineering at Michigan State University, USA. His current research interests are in the control of ac machines and PV power generation.



Eui-Cheol Nho was born in Korea in 1960. He received the B.S. degree in Electrical Engineering from Seoul National University, Korea, in 1984, and received the M.S. and Ph.D. degrees in Electrical and Electronics Engineering from KAIST, Korea, in 1986 and 1991, respectively. Since 1995, he has been a member of the faculty in the Department of Electrical Engineering, Pukyong University, Korea. He was with the Department of Electrical Engineering, University of Wisconsin-Madison, USA as a visiting scholar from 1997 to 1998. From 2005 to 2006, he also served as a visiting scholar with the Department of Electrical Engineering and Computer Science at the University of California, Irvine, USA. His current research interests are the control of dynamo UPS, power line conditioners, etc.